

GRANCH

Be conscientious manner to offer you our best service.
Benefit to customers ; Value to ourselves.

CTS中心出水齒輪幫浦 CTS Spindle Coolant Gear Pump

GP33系列高壓齒輪 切削油系統幫浦



本系列齒輪泵之特點

流量穩定，低噪音，低轉速
可建立壓力，可搭配節能，
適用於油壓，(CTS)中心出
水，深孔加工系統。

The characteristics of this series of gear pumps:

Spit pulsation is small, flow is
accurate, Continuous operation
and stability, long life, Suitable for
Spindle Coolant (water soluble)
Cutting oil system, deep hole
machining.

Head Office

宏茂事業有限公司 GRANCH ENTERPRISE CO., LTD.

台中市北區健行路766巷32號

Tel : 04-2205-5738

Fax : 04-2205-5750

Email : granch@granch-filter.com

台灣工廠

台中市烏日區溪南路一段680巷568-1號

Tel : 04-23359261



www.granch-filter.com



GRANCH

Be conscientious manner to offer you our best service.
Benefit to customers ; Value to ourselves.

型式號碼表示法 / MODEL NUMBER DESIGNATION

GP33	-※※	-F	R
型號 Model	吐出容積 Delivery Capacity cc/rev	安裝方式 Mounting Type	心軸轉向 Shaft Rotation
GP33	10,20	F: 法蘭型 Flang Type	R: 順時針 Clockwise

注意事項 /

油水比例：5%

吐出脈動小，流量精準，
連續運轉安定，壽命長，
適用於中心出水(水溶性)
切削油系統，深孔加工。

幫浦性能表 / SPECIFICATION

型號 Model	最高壓力 Max Pressure kg/cm ²	吐出量 Output flow cc/rev	配管尺寸 Ports size		重量 Weight(kg)
			出口 Out	入口 In	
GP33	140	20	1/2"	1"	16.8



外觀尺寸圖 /

DIMENSION(IN MILIMITERS)

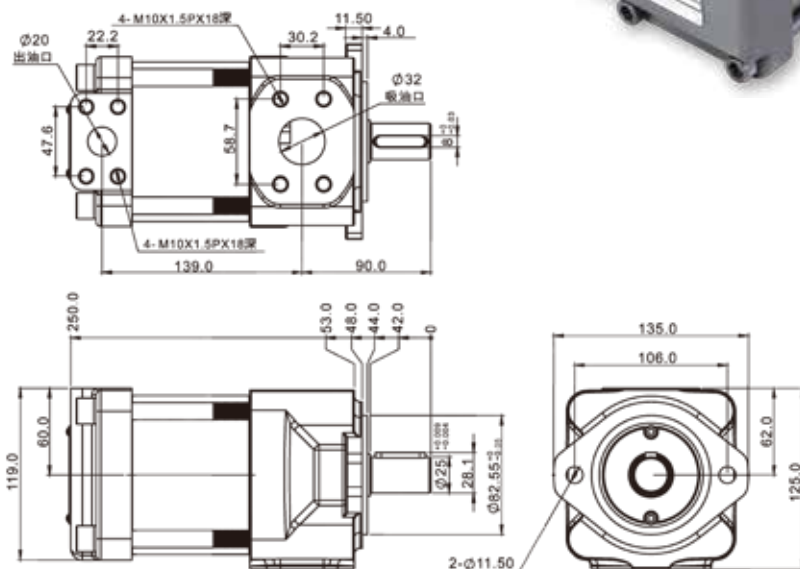

China Branch

昆山利景亨精密機械有限公司 GRANCH ENTERPRISE CO., LTD.

江蘇省昆山市巴城鎮新澄路78號

Tel : +86 0512-36881876 / Fax : +86 0512 36861679

<http://www.twhmao.com>

